

Ball Theater

La fête n'est pas finie

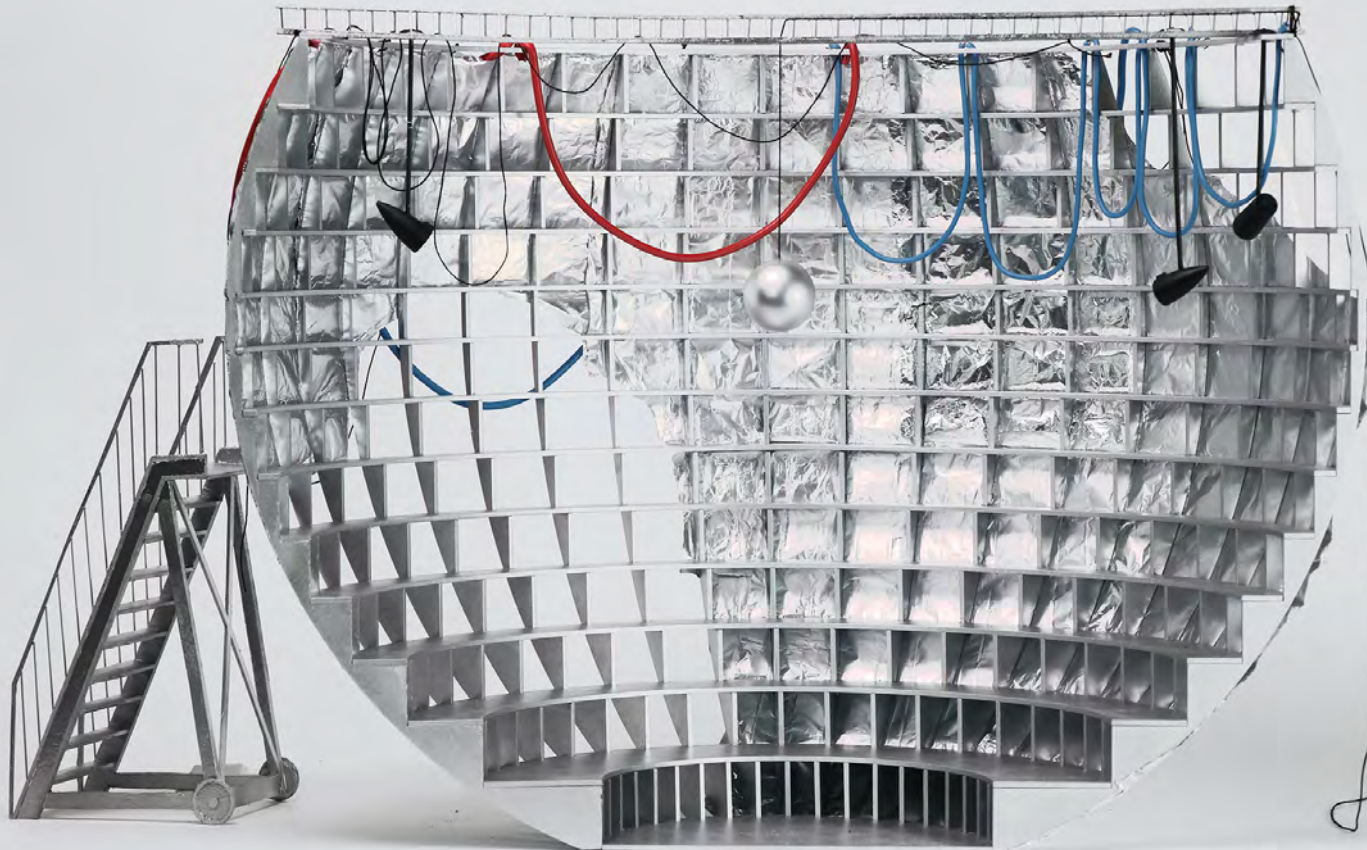

FRENCH PAVILION

18th Venice International Architecture Biennale

20 may - 26 november 2023

The artistic team

Lead curators : **muoto** + Georgi Stanishev

Scenography : Georgi Stanishev + Clémence La Sagna

Associate curator : Jos Auzende

Program management : Jos Auzende et Anna Tardivel

Sound design : Cédric Pilooski, Alain Français, Thomas Fourny

Lights : Les Ateliers de l'Eclairage

Ball Theater

The *Ball Theater's* response to the “Laboratory of the future” theme selected by Lesley Lokko is a spectacular sound architecture, an alternative space for reflection, and a laboratory of imagination and festivity.

The theater takes the form of a light and modular sphere, conceived as a laboratory of identities. It adopts a poetic and utopian dimension that explores the notion of growth. It can be interpreted both as a foretaste of the future and as a multifaceted sphere that dramatizes the interplay of sound, space and bodies. It becomes the arena for a monthly cycle of workshops-residencies-events in which a multiplicity of voices and narratives take to the stage, opening up the theater to the world and its planetary challenges. It functions like an echo chamber, resonating with topical issues around the fragility of the planet, our colonial heritage, our representations of identity and gender. It suggests a new approach to today's crises, based on questioning, letting go, seeking alternatives and building on different visions.

The party's not over!





The theatre : a sound architecture

A nonvisual but perceptible connection links the hemisphere and all the objects together, a connection that you discover as you move around. It consists of directional acoustic pathways, sounds that bounce from one room to the next, creating a spatial experience of sound. This acoustic environment, made up of voices and whispers, immerses visitors in a form of abstract, non-verbal language that precedes words and stimulates new forms of attention. Noises, songs, voices, murmurs... the sound space evolves over time shaped by an AI system and an original arrangement of 36 speakers, which creates a "slow listening" ambience. In a world saturated with visual signs and images, this soundscape devised by the theater's sound team, the electronic music composer Pilooski (Cédric Marszewski) and the sound engineers Alain Français and Thomas Fourny, suggests that utopia is only possible if one can briefly drop out of the dominant culture, if one can de-familiarize oneself with language and conventional expression.

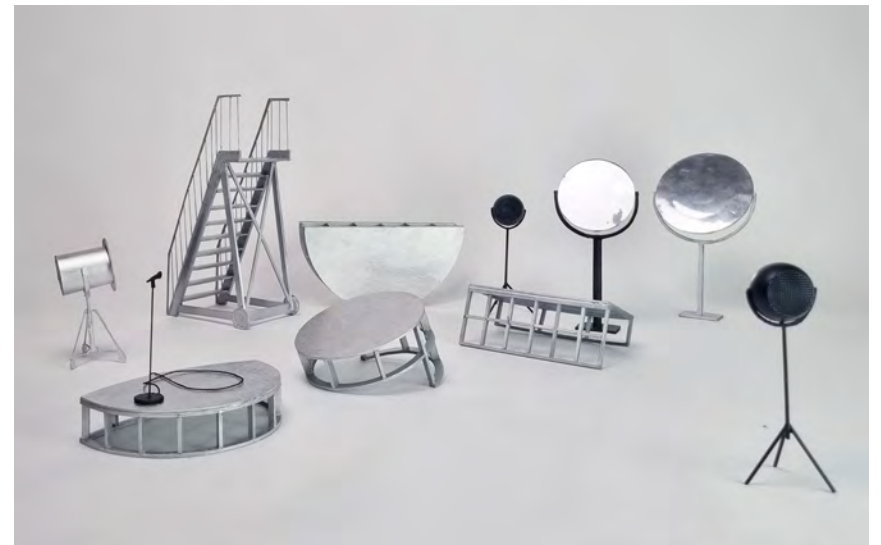
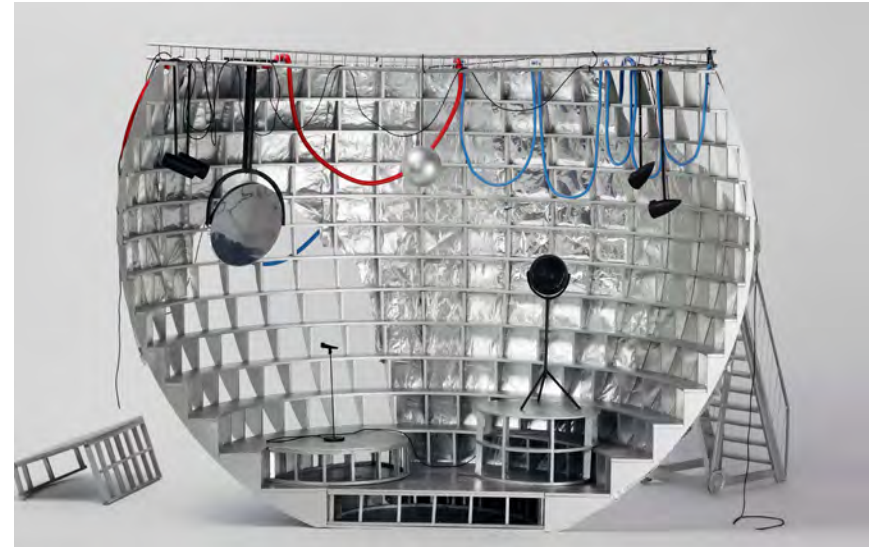

Sound scheme

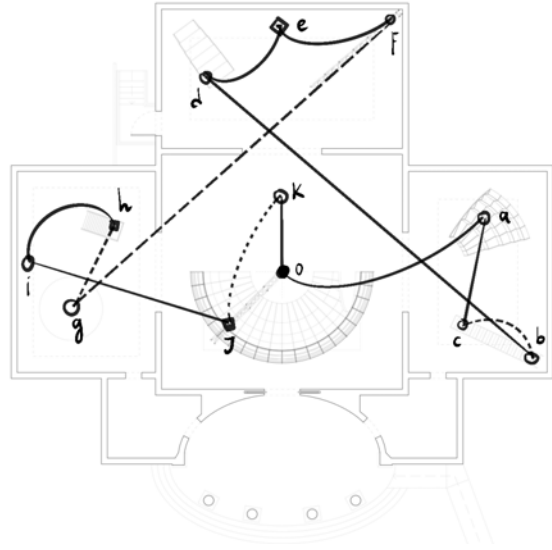

Interactive microphone



Central server



A low-carbon strategy

Local production and limited travel

The French Institute, operator of the French Pavilion, is setting up a low-carbon measurement tool for this biennial event in order to reduce the impact of its projects. According to its study, the production of materials and travels are the first two factors of emission. The production of the structure is therefore entirely manufactured in the Veneto region of Italy and all the team will only travels by train to Venice.

A traveling theater

The wood-steel structure of the bleachers is light, modular and removable. It responds to a low-tech modular construction method allowing to use a minimum of material. The cutting in small parts allows an easy assembly and disassembly. This constructive mode allows the structure to travel after the biennial event, to be installed in other places and to host events. The challenge is to allow the definitive acquisition of the theater by one of the institutions that will host it in its post-biennial odyssey.

Re-use

All the objects that occupy the theater and the three adjacent rooms are found in Italy and restored on site, in order to find a new use during the Biennale. The itinerancy of the theater will allow them to know another life.



Ball Theater : post-biennale

Deliverables

- a spectacular architectural and sound installation, conceived for different occupations
- “revelatory found objects” that challenge our systems of attention and response
- a series of public events – the BALLS – led by artists and scientists
- a touring program to share the questions in other contexts, in France and abroad
- a website and ‘open-source’ content to showcase and share the experience remotely

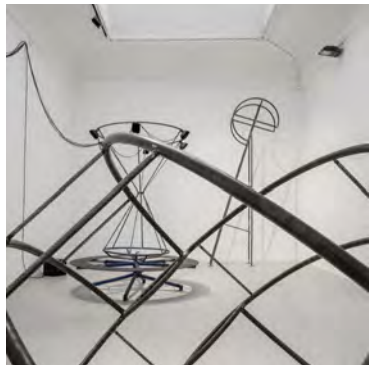

I. The demi-sphere



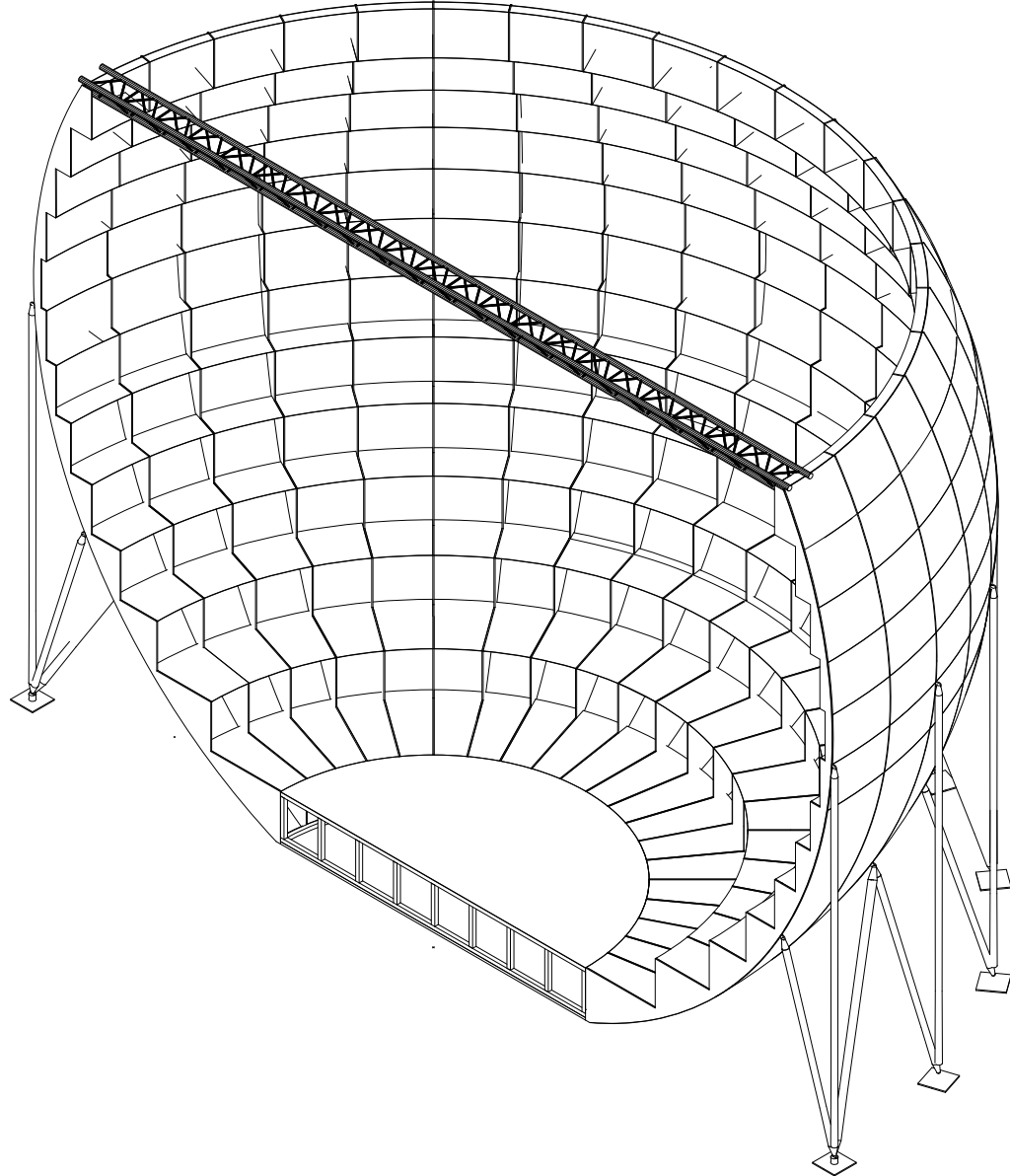



Sphère : Plan + 2.25m

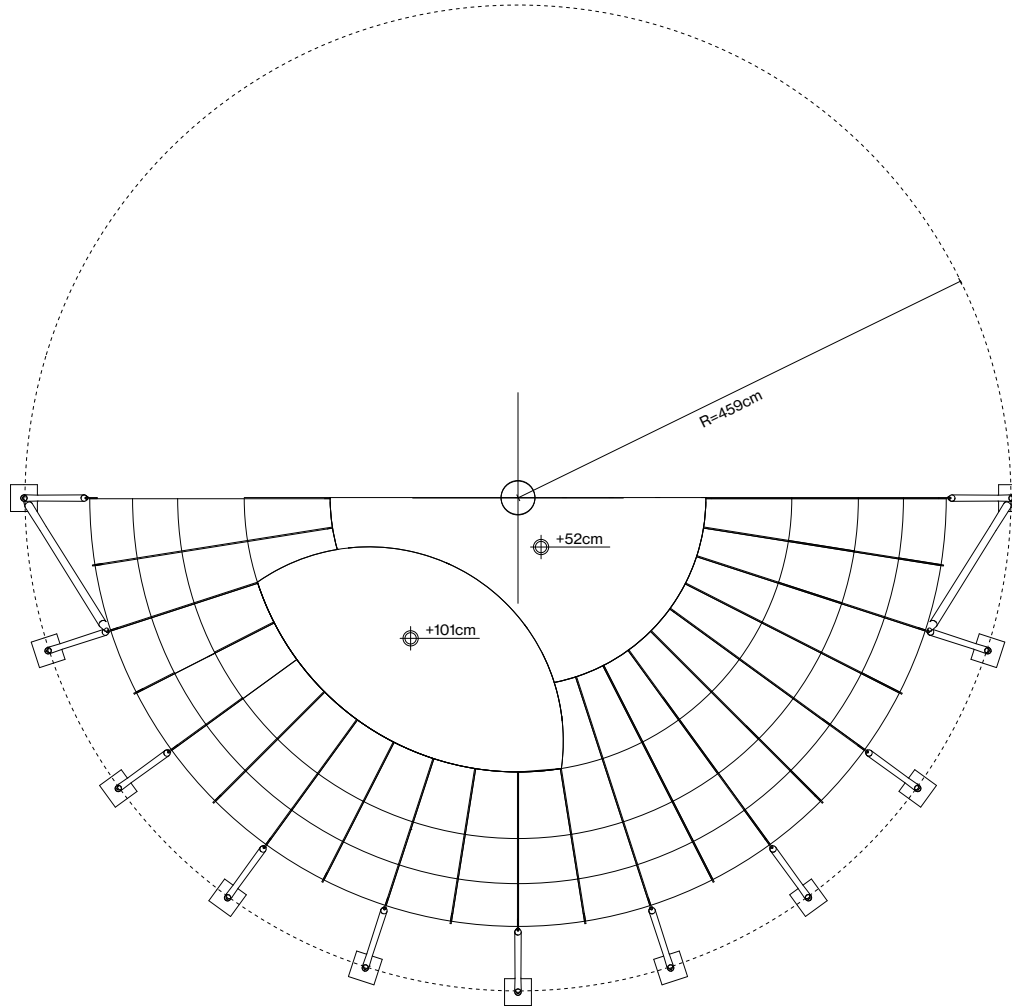

0 1 2 3m

Sphère : Plan général

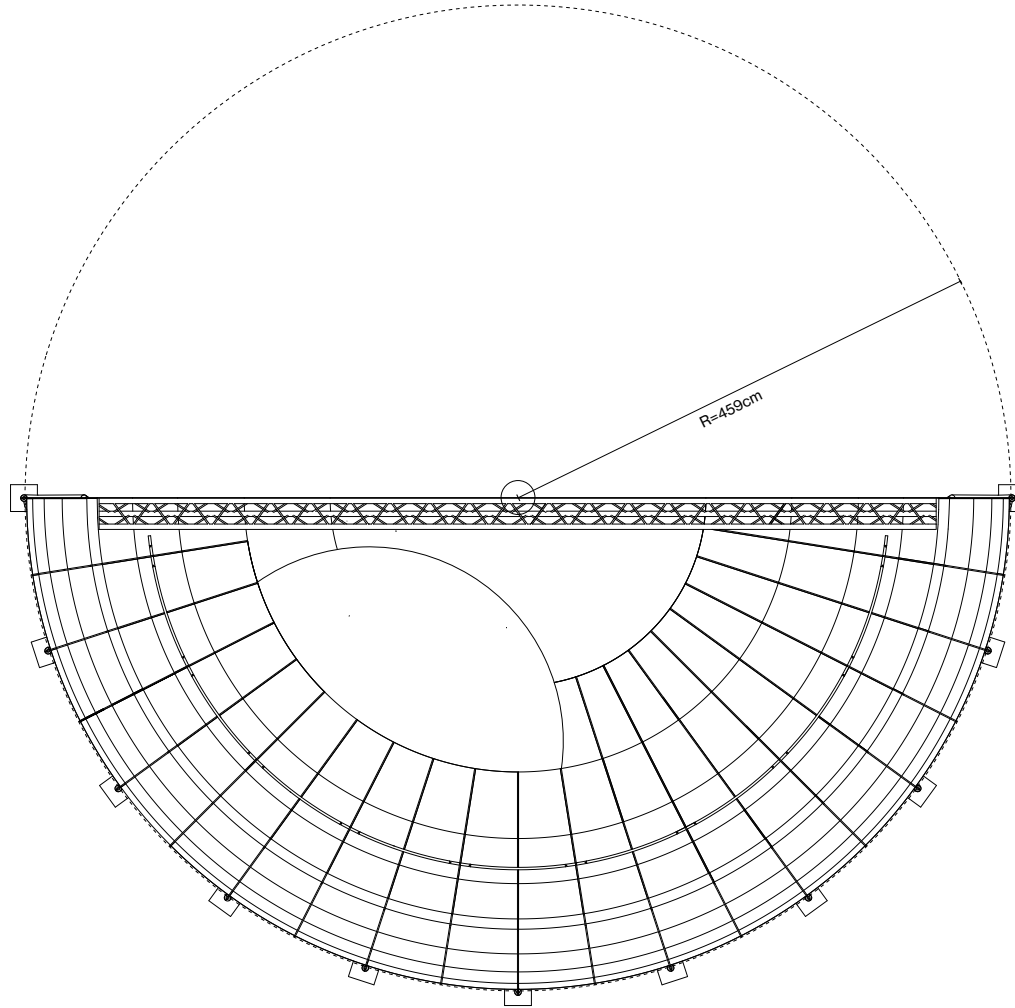



Sphère : Coupe longitudinale

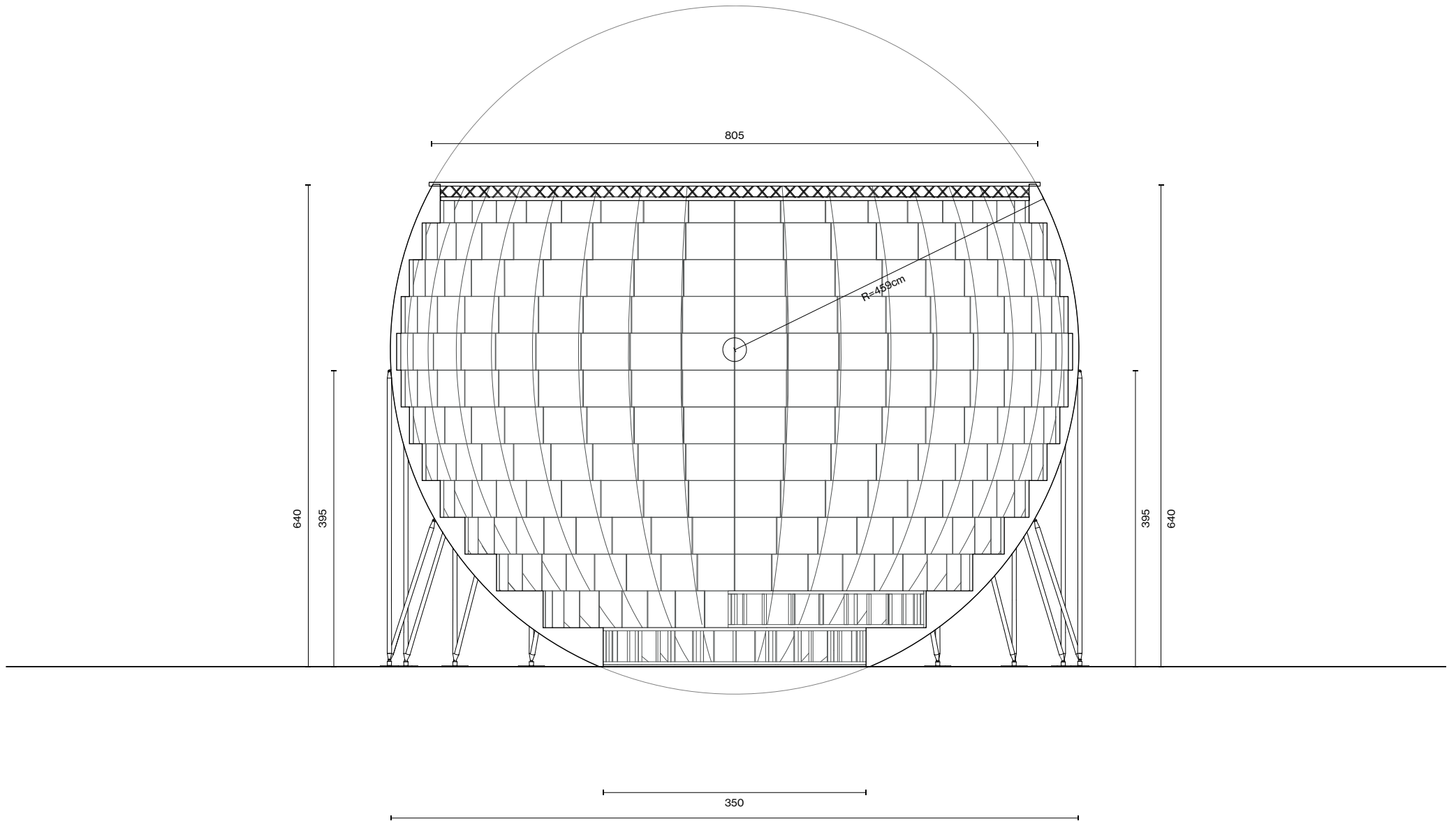

0 1 2 3m



Sphère : Coupe transversale

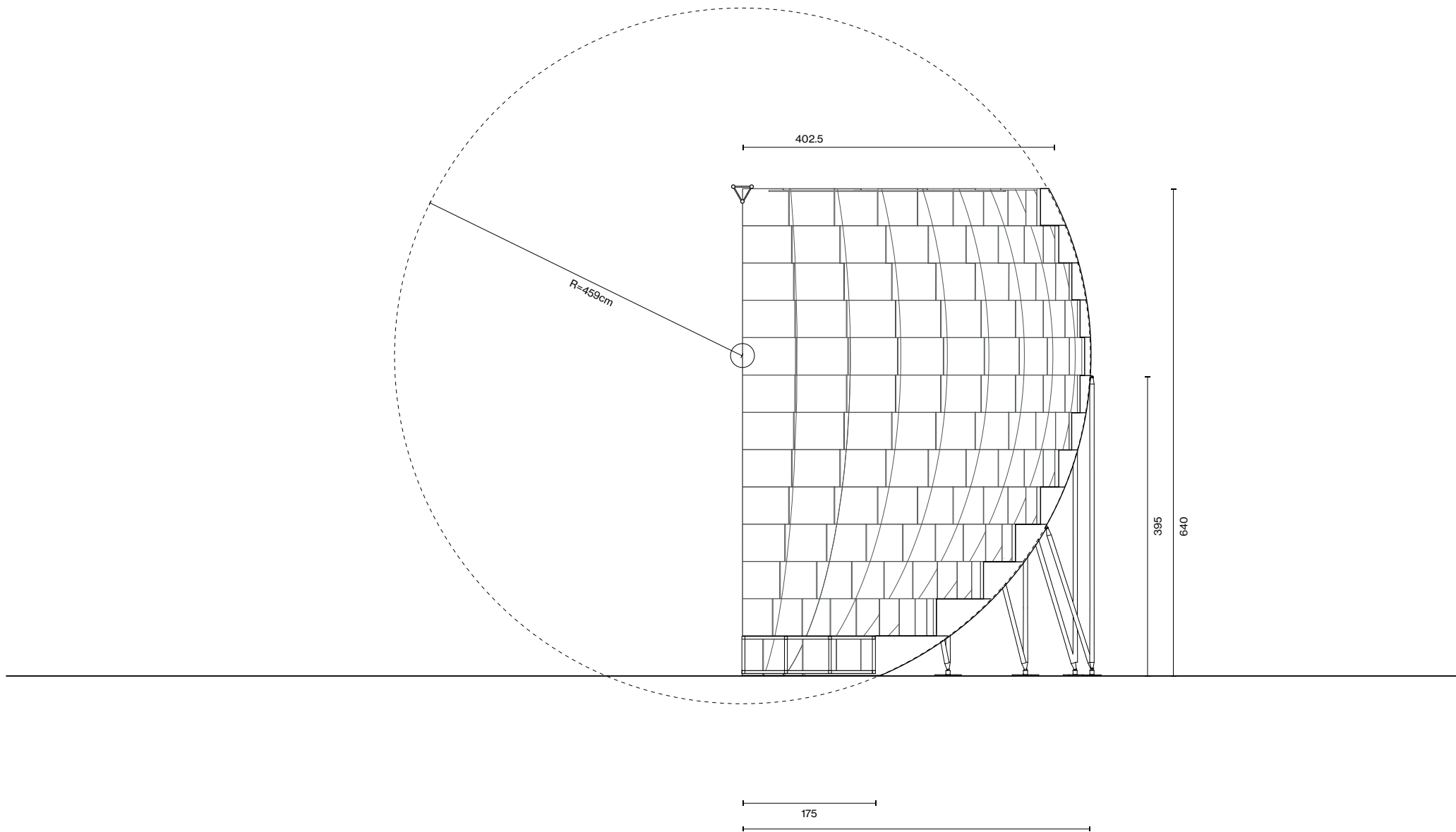

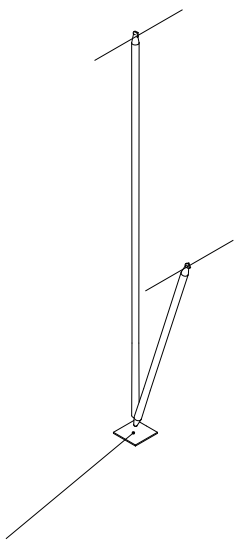

Étais en 'V'
acier galvanisé
boulonné sur les méridiens
boulonné au sol

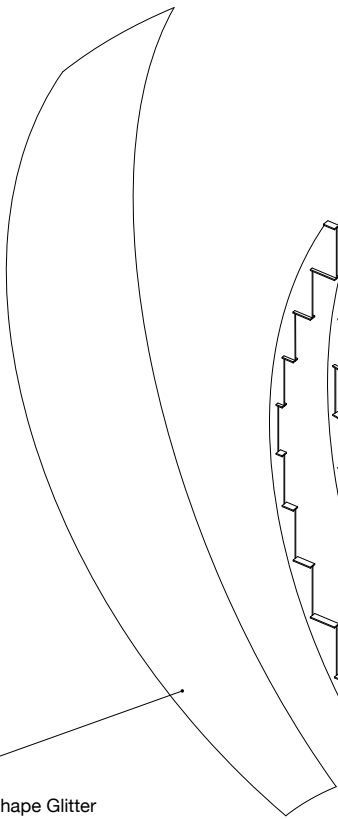

Revêtement
feuille aluminium Alushape Glitter
posé manuellement sur la structure

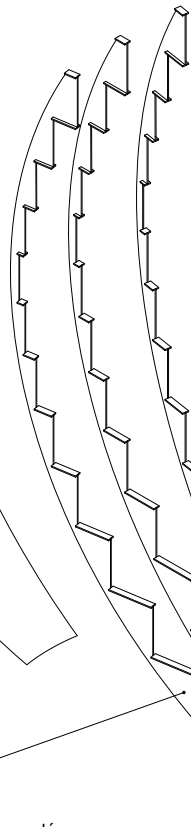

Méridiens (21 rayons)
platine verticale 10mm
avec platines de fixation soudées
boulonnées à la base
acier galvanisé

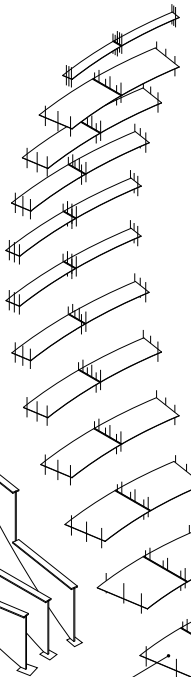

Parallèles (13 niveaux)
platin horizontales 3mm
boulonnées au méridiens
acier galvanisé

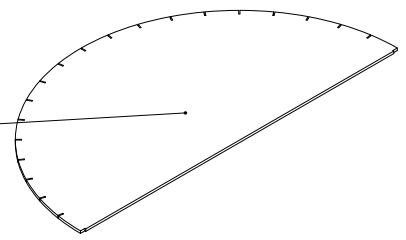

Base
platine horizontale 10mm
boulonnée au sol
encoches pour les méridiens



Demi-sphere

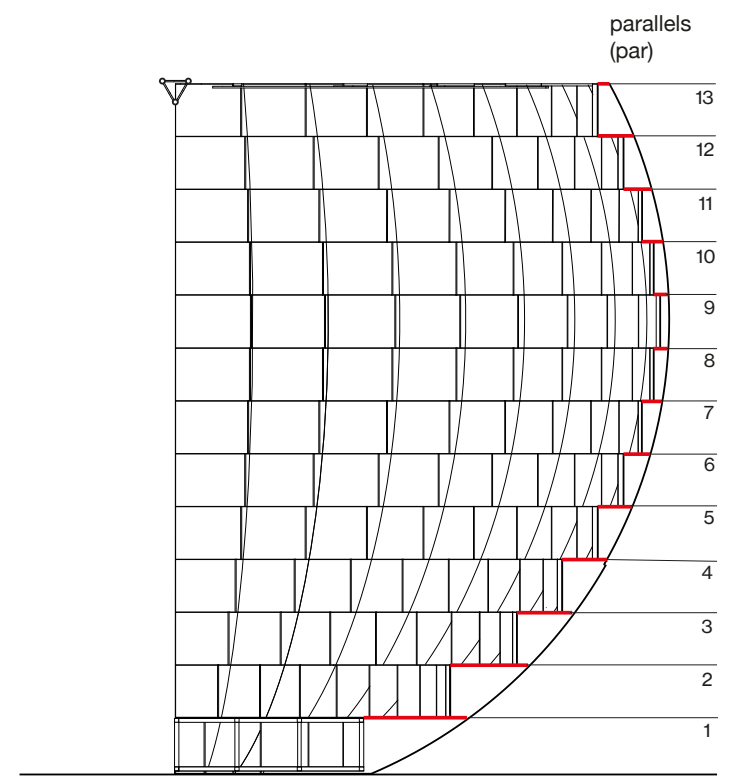
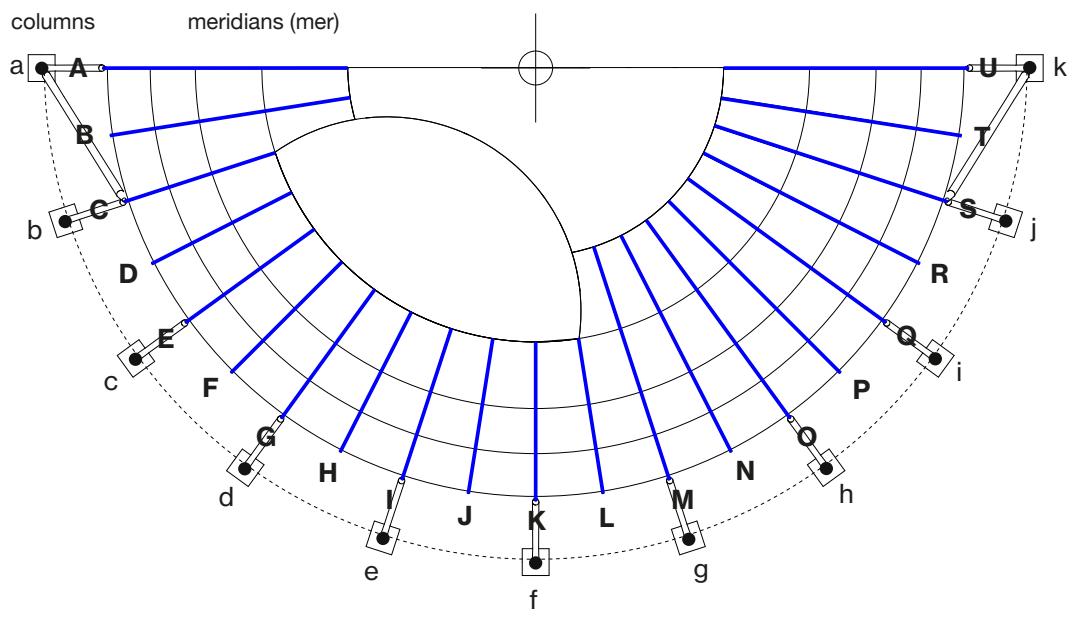
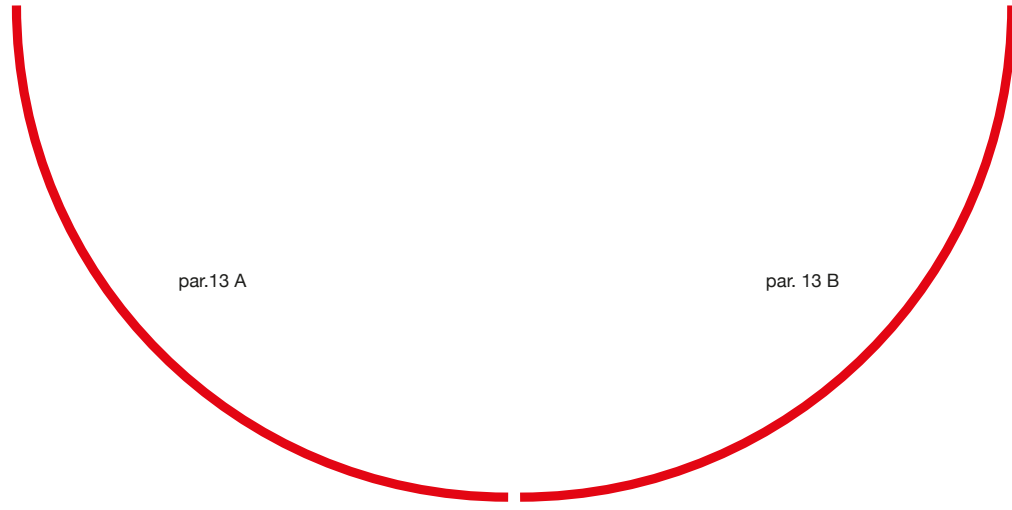

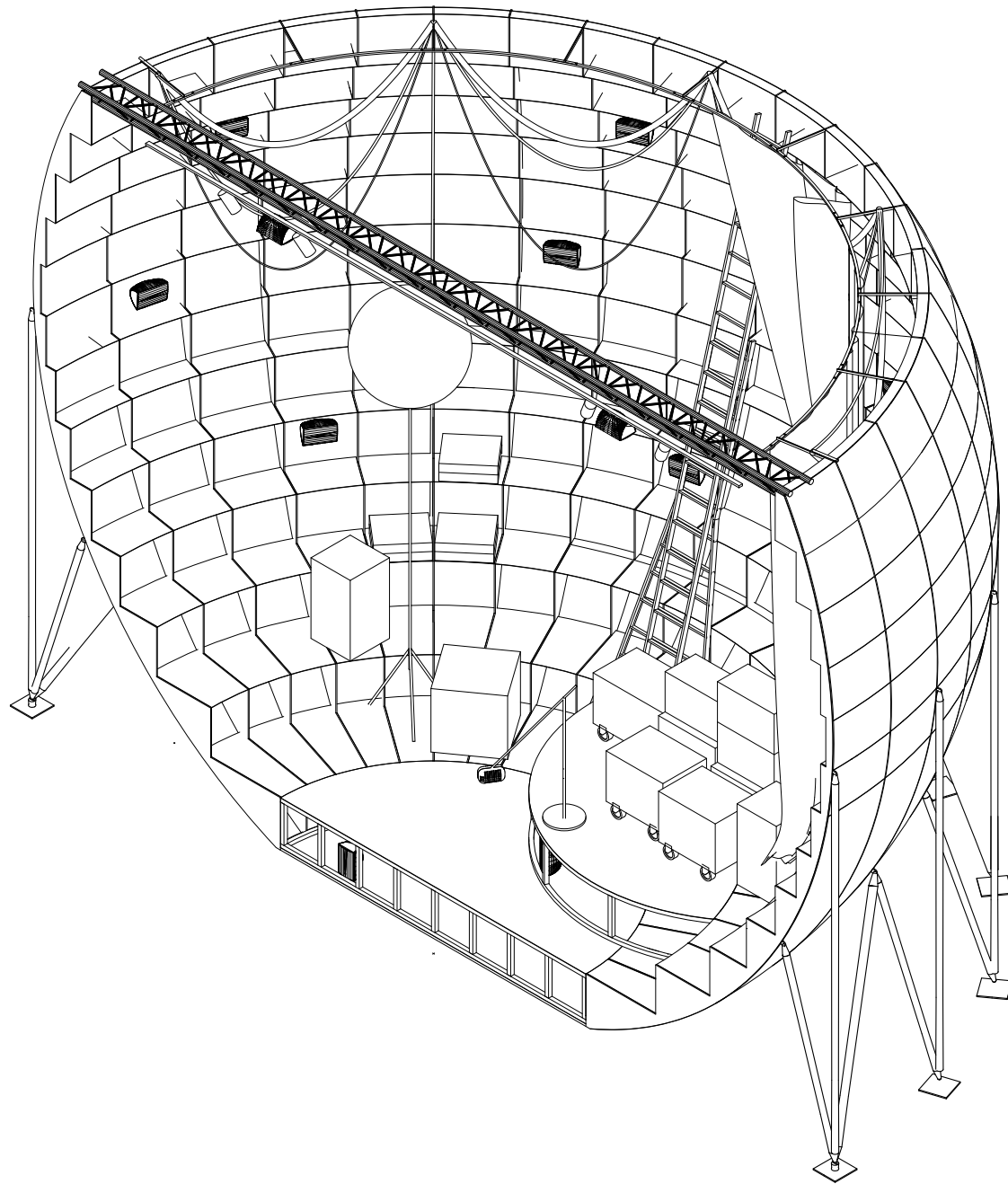

0 1 2 3m

Gradins

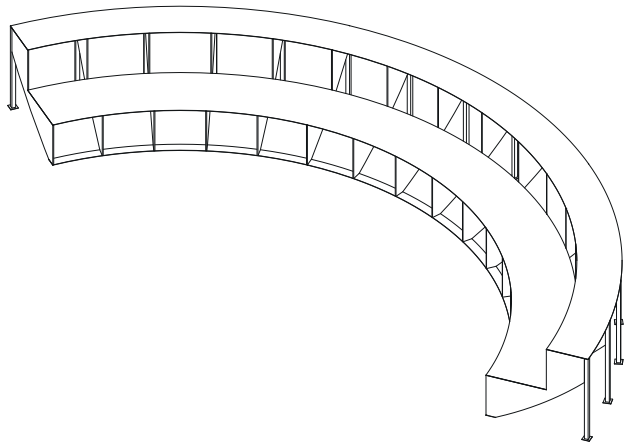

AXONOMÉTRIE

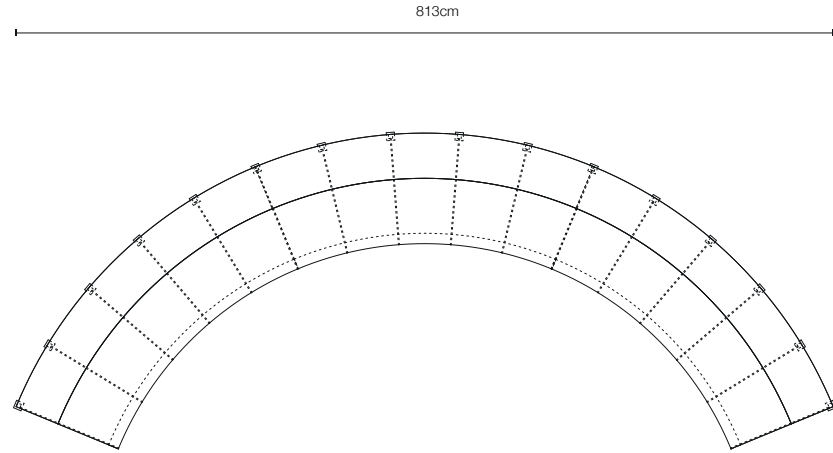

PLAN

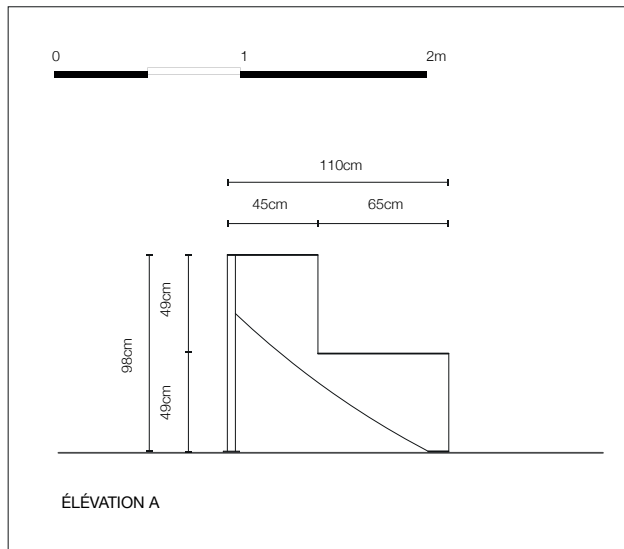

ÉLÉVATION A



ÉLÉVATION B



Bleachers

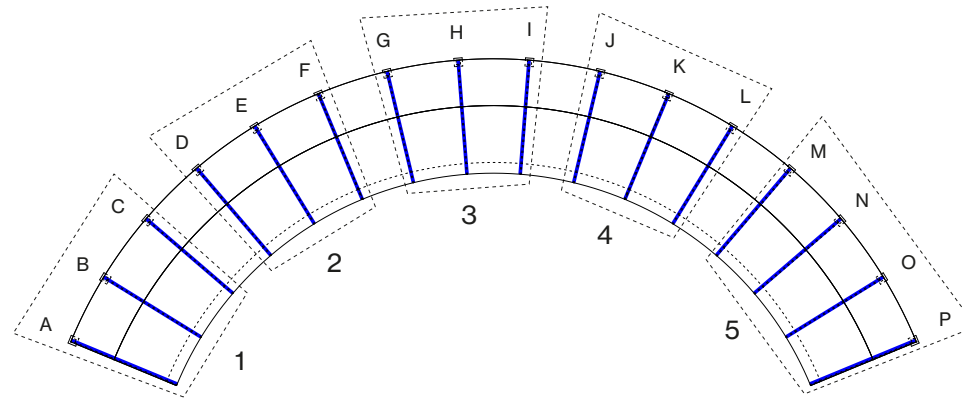

structure
bleacher

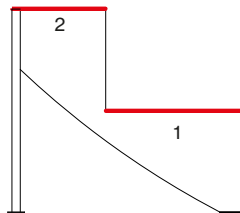

bleachers
(bl)

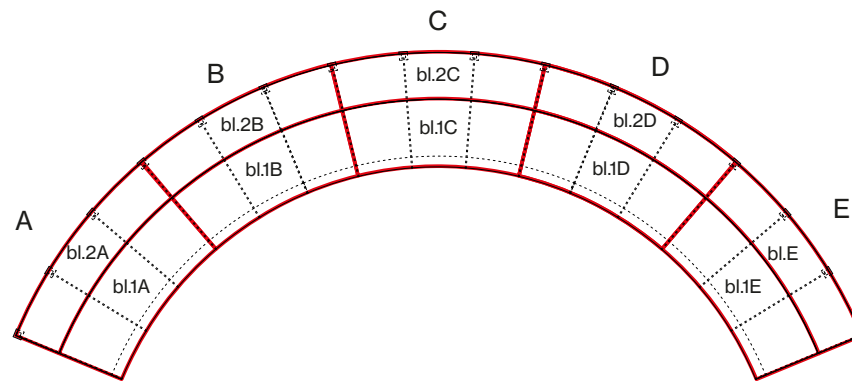







II. The found objects





Merry-go-round

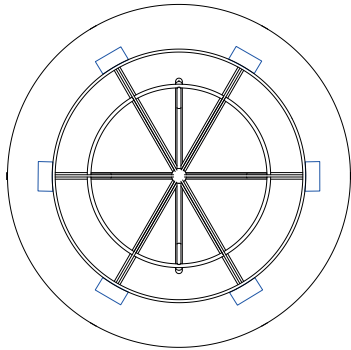
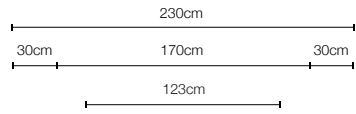

PLAN

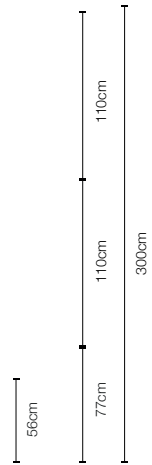
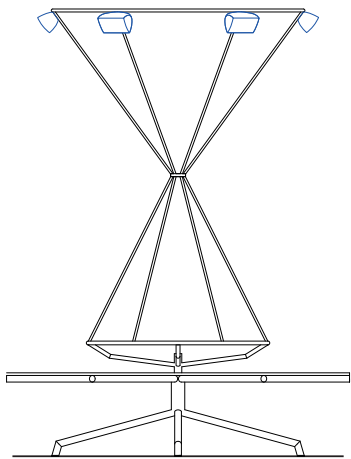

ÉLÉVATION A





German wheel

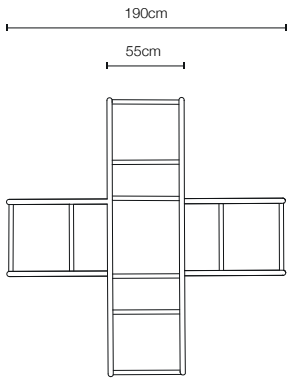

PLAN

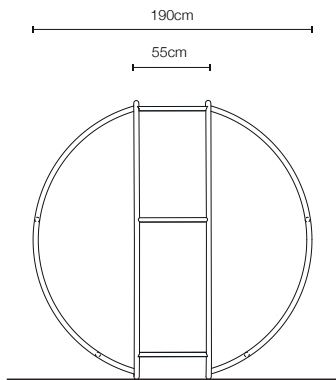

ÉLÉVATION B



0 1 2 3m

Big mirror

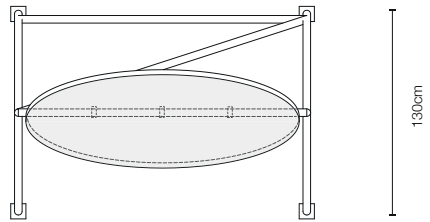

PLAN

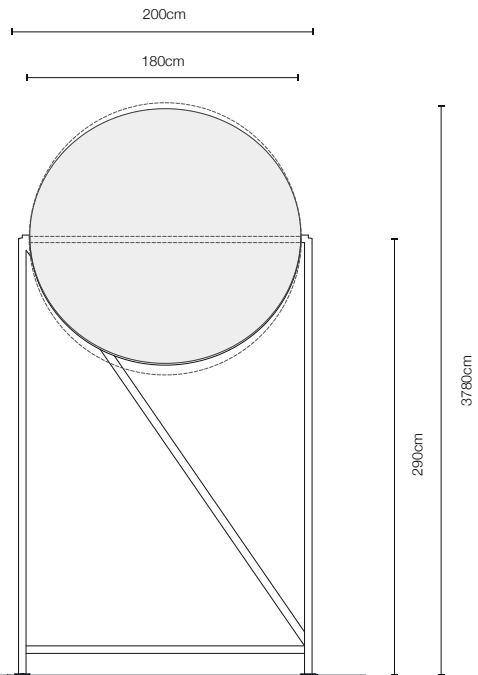

ÉLÉVATION B



0 1 2 3m

Mirrors

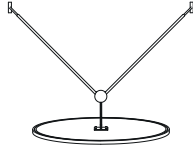

PLAN

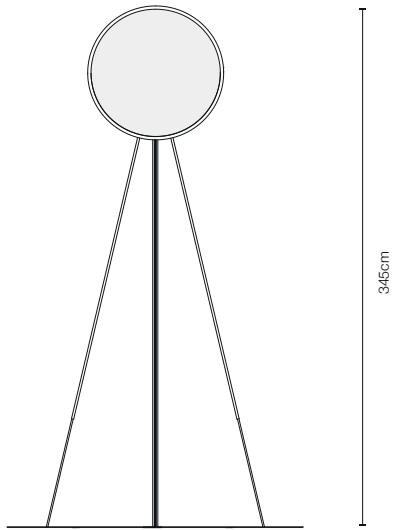

ÉLEVATION B



0 1 2 3m

Posts

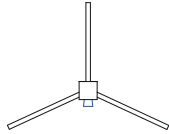

PLAN

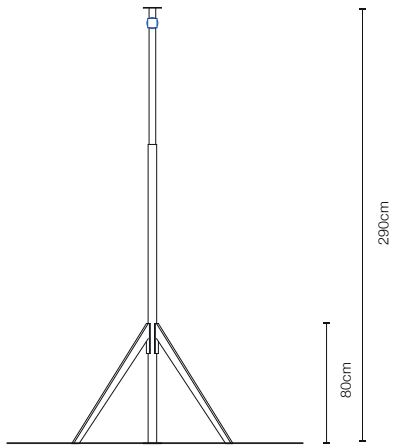

ÉLÉVATION B





Table

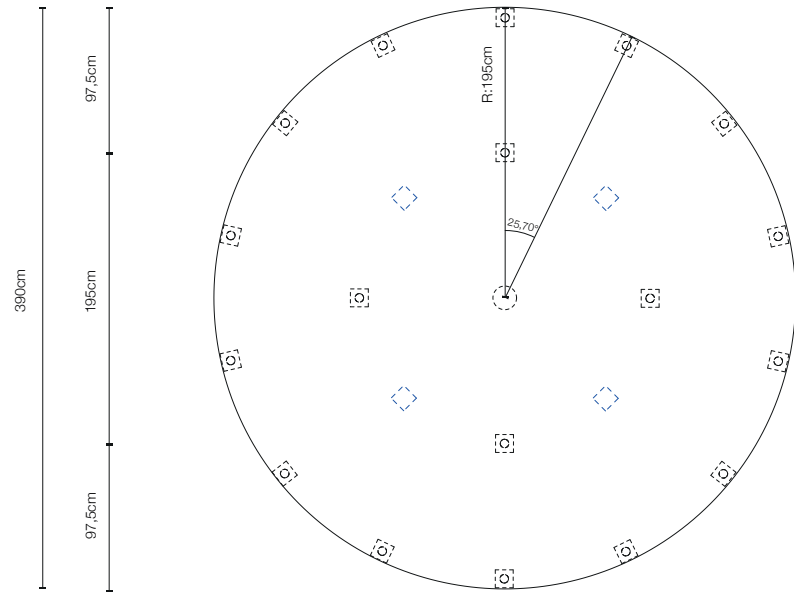

PLAN

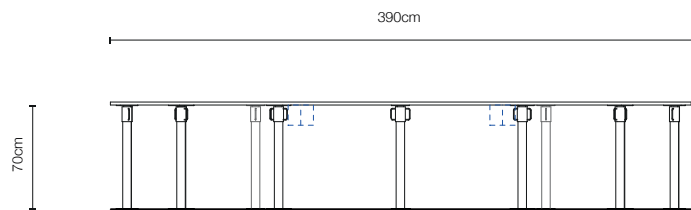

ÉLÉVATION A



0 1 2 3m

Ladder

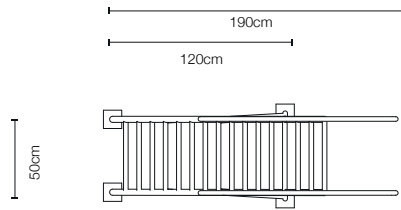

PLAN

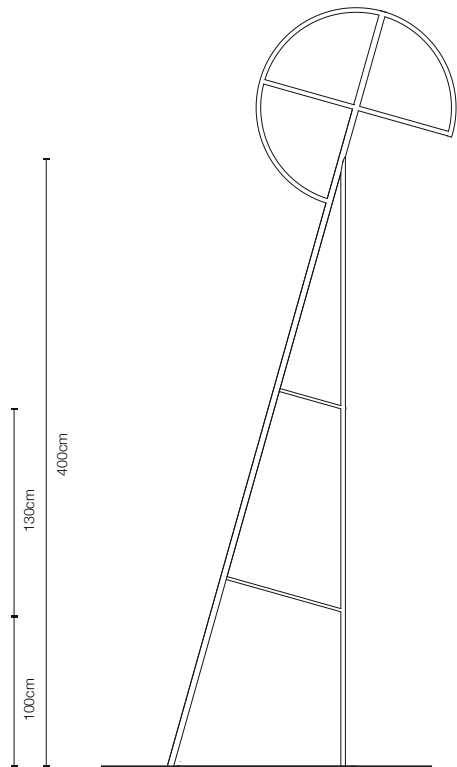

ÉLÉVATION B



APPENDIX

FRANCIA





Plan général

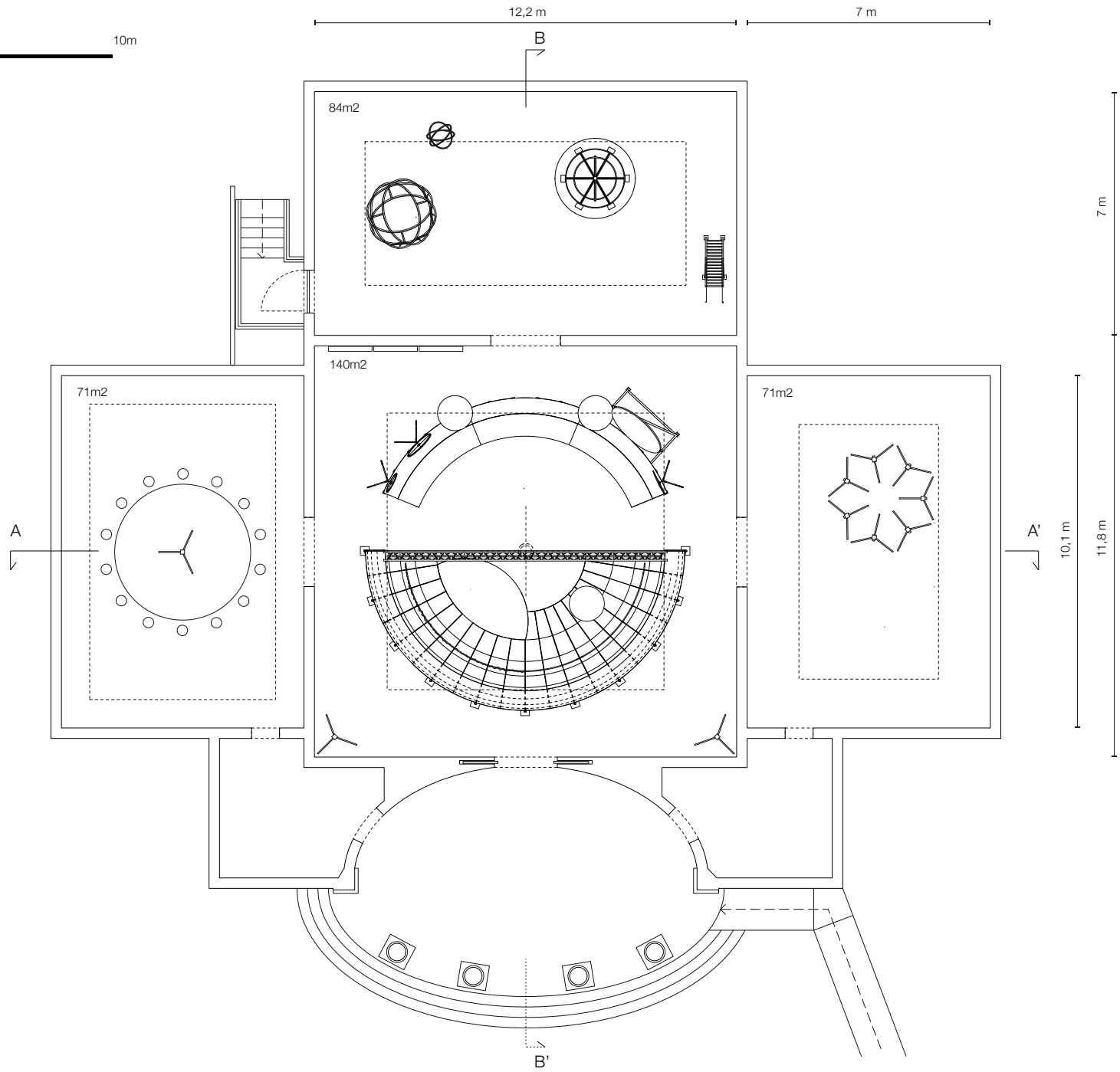

0 1 2 3 5 10m

Plan
Installation sonore

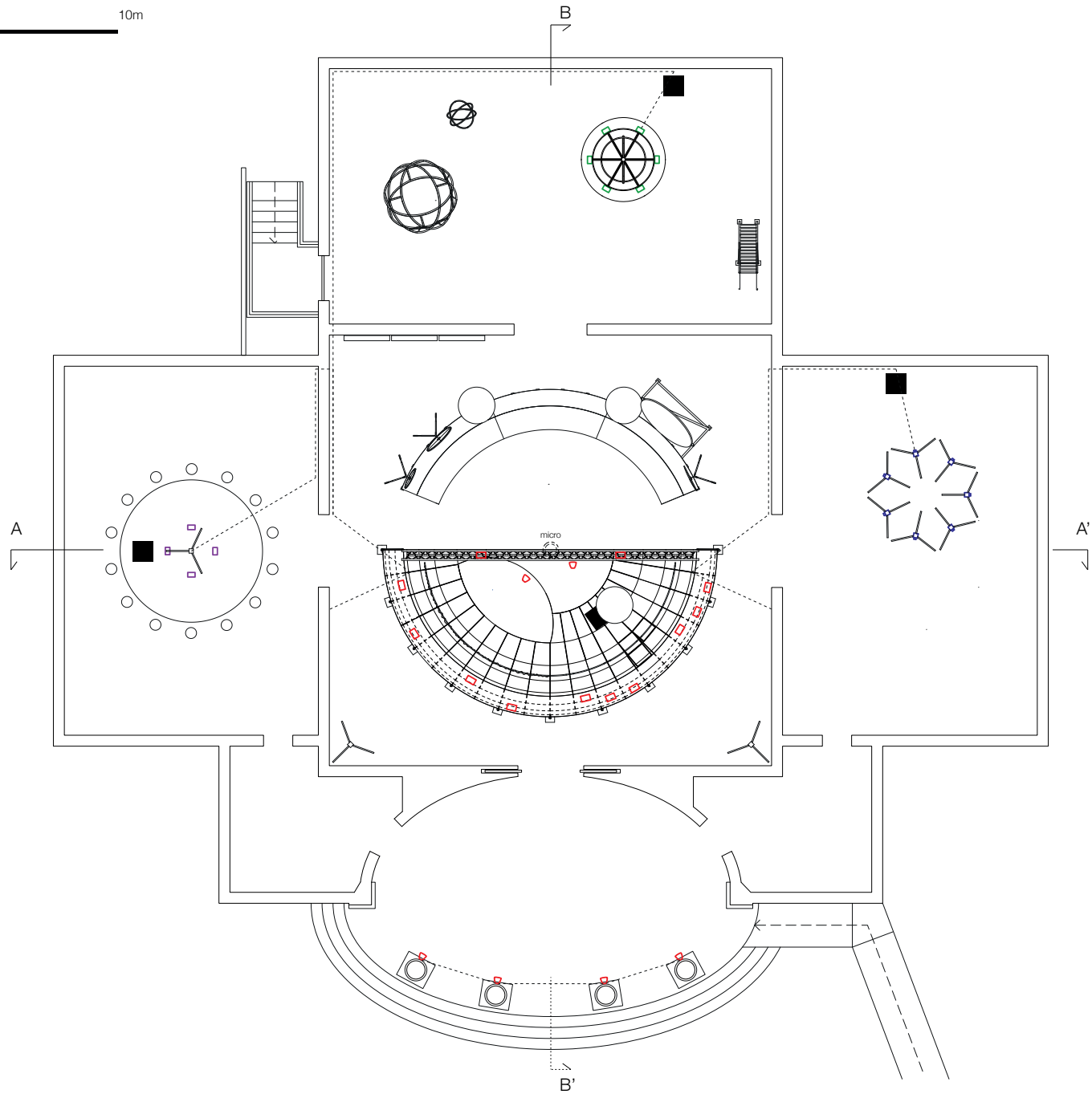



- câbles suspendus
- Ampli
- Yamaha VXS1
- Yamaha VXS3
- Yamaha VXS5
- Enceintes vibrantes
- Sub

0 1 2 3 5 10m

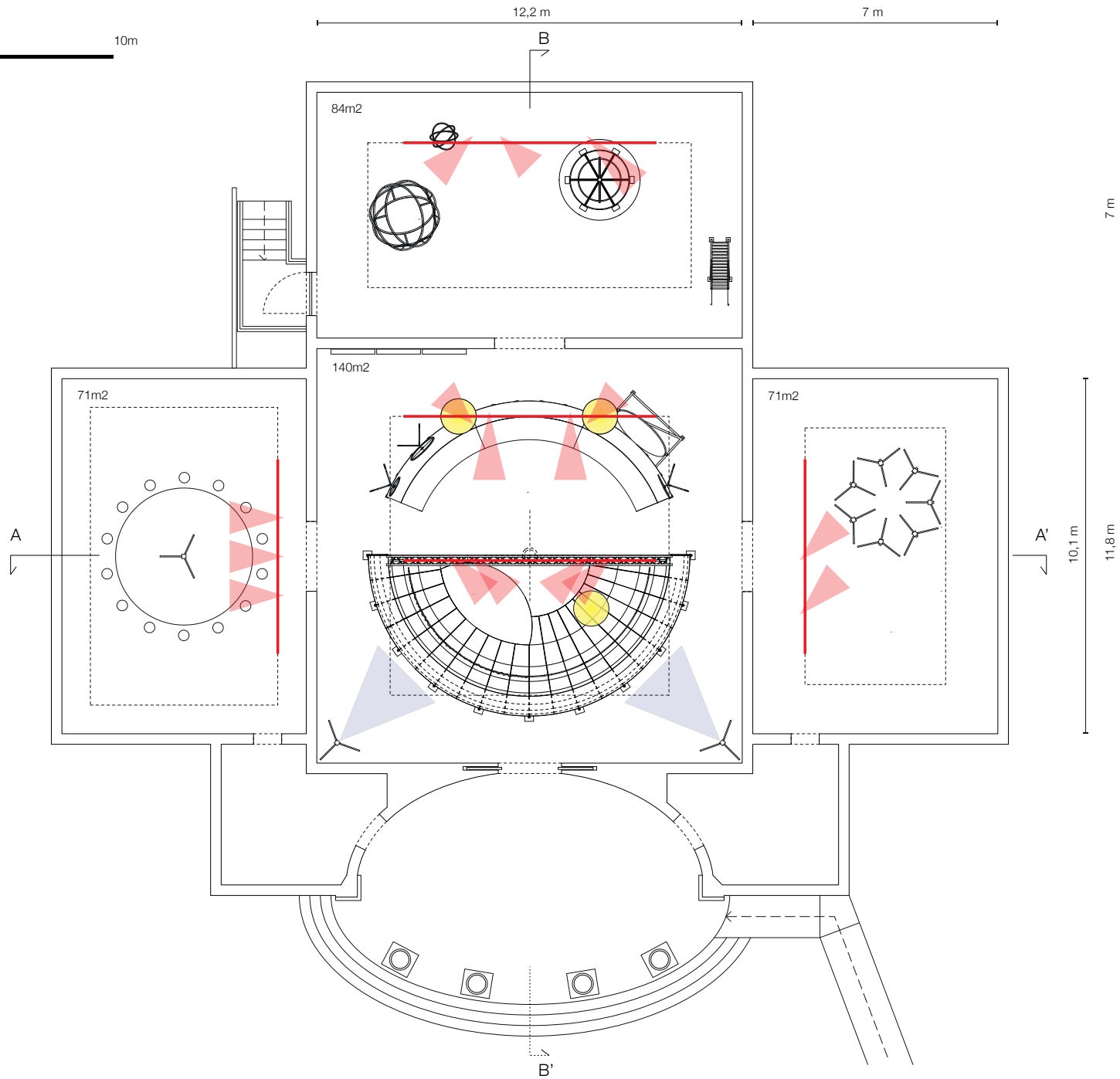
Plan
Éclairage



-  Ballons lumineux 2u
-  Projection entrée 4u
-  Éclairage rail 14u

0 1 2 3m

Plan espace central
140m²

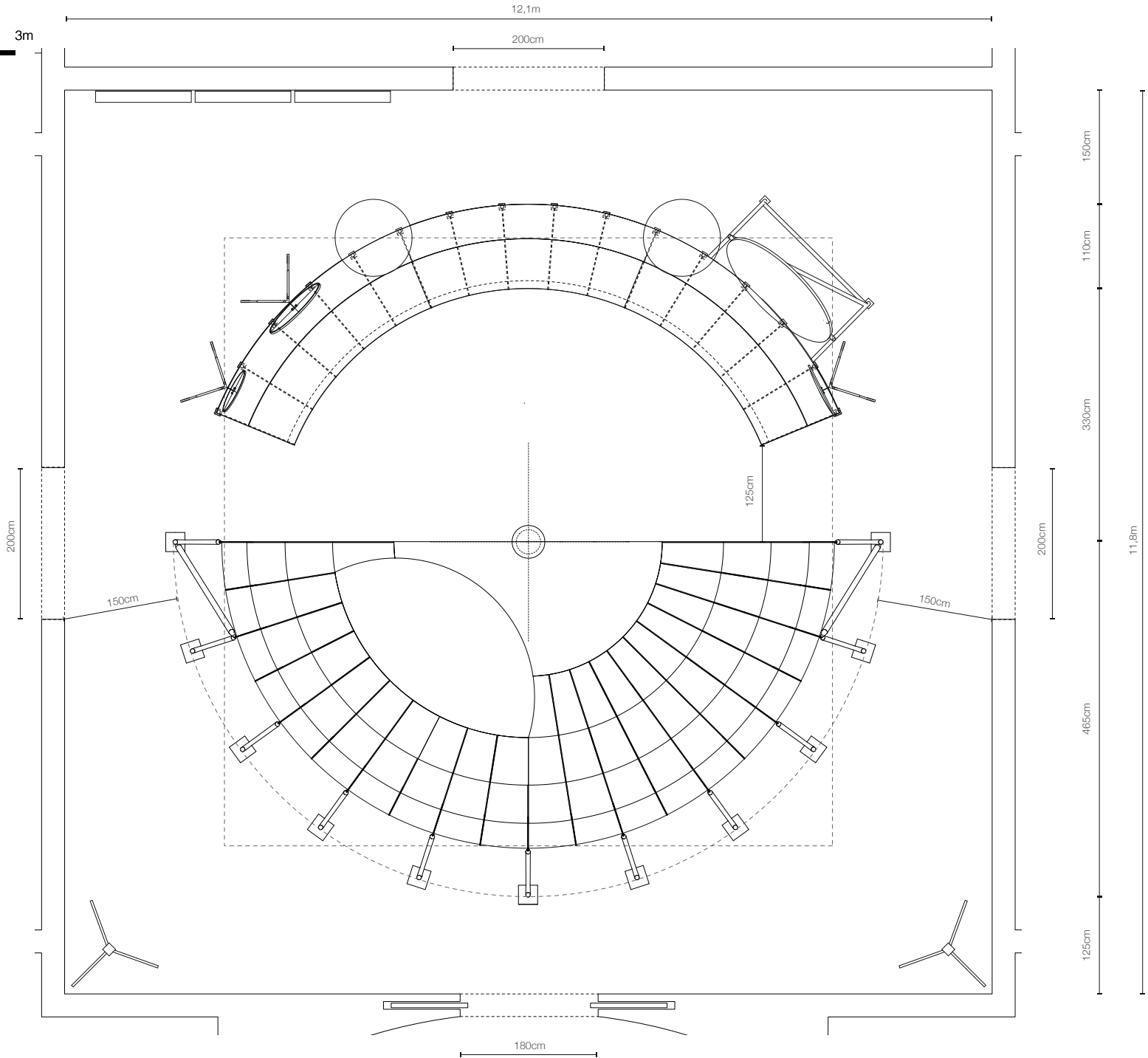

0 1 2 3m

Espace central : Coupe AA'

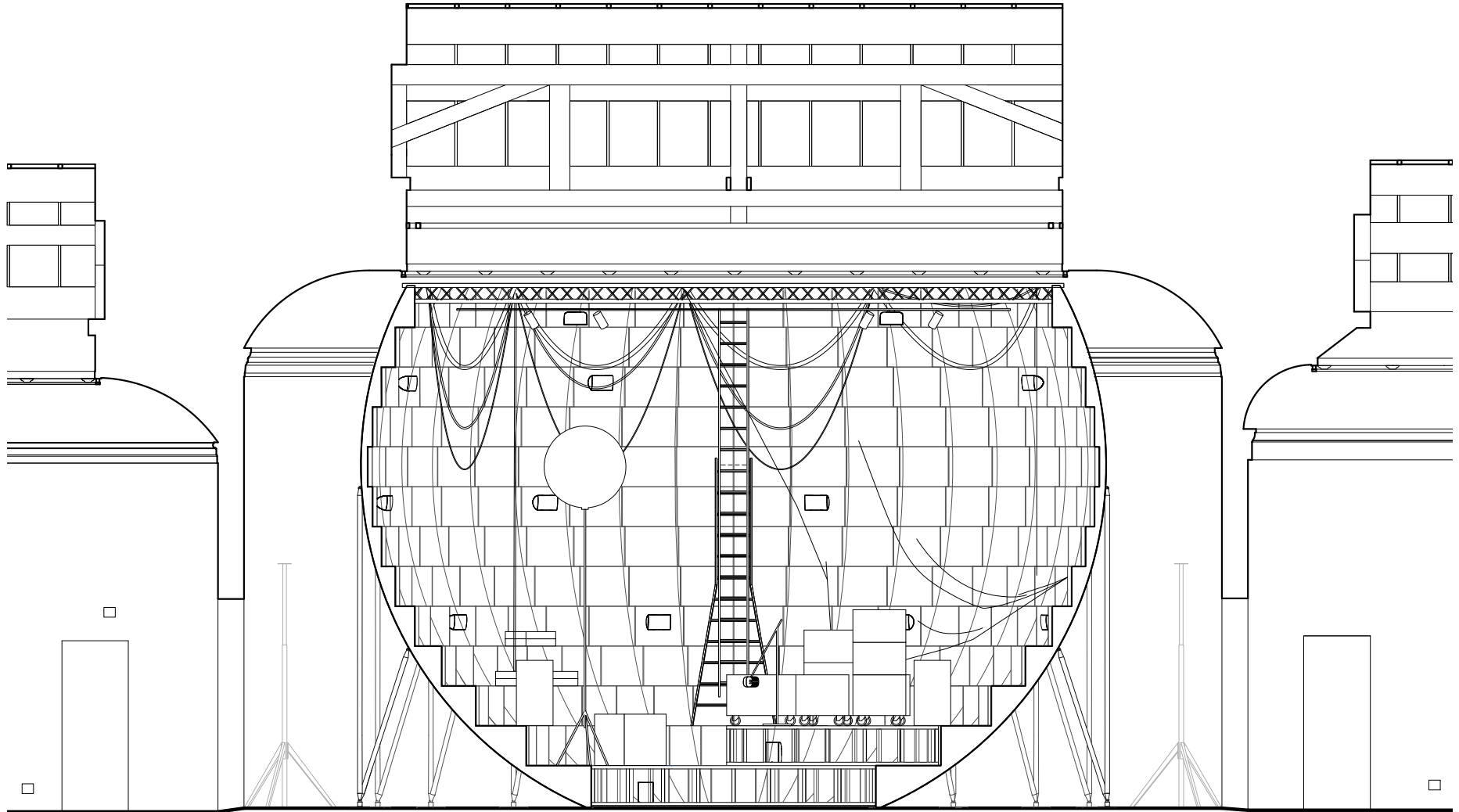

0 1 2 3m

Espace central : Coupe BB'

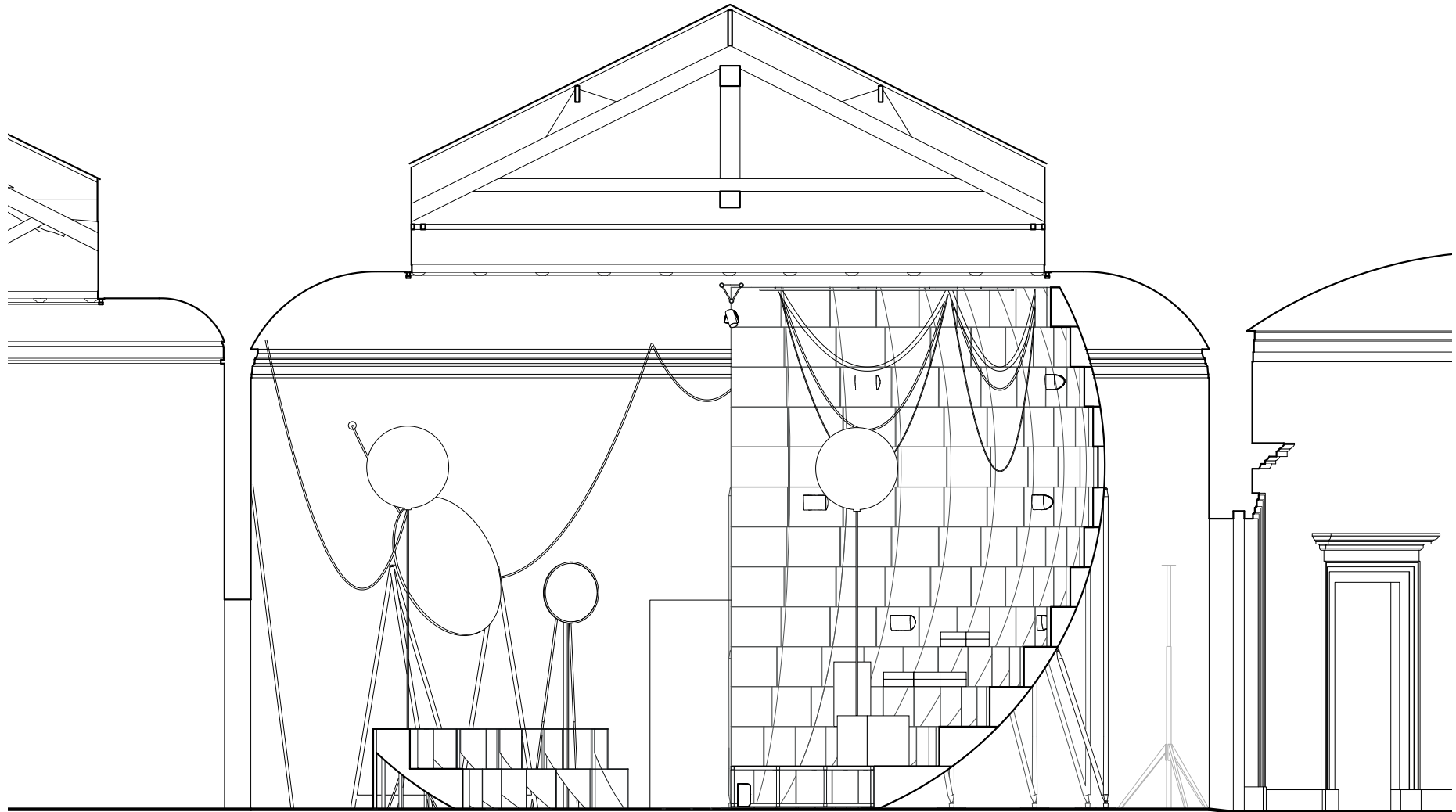

0 1 2 3m

Salle du fond
84m²

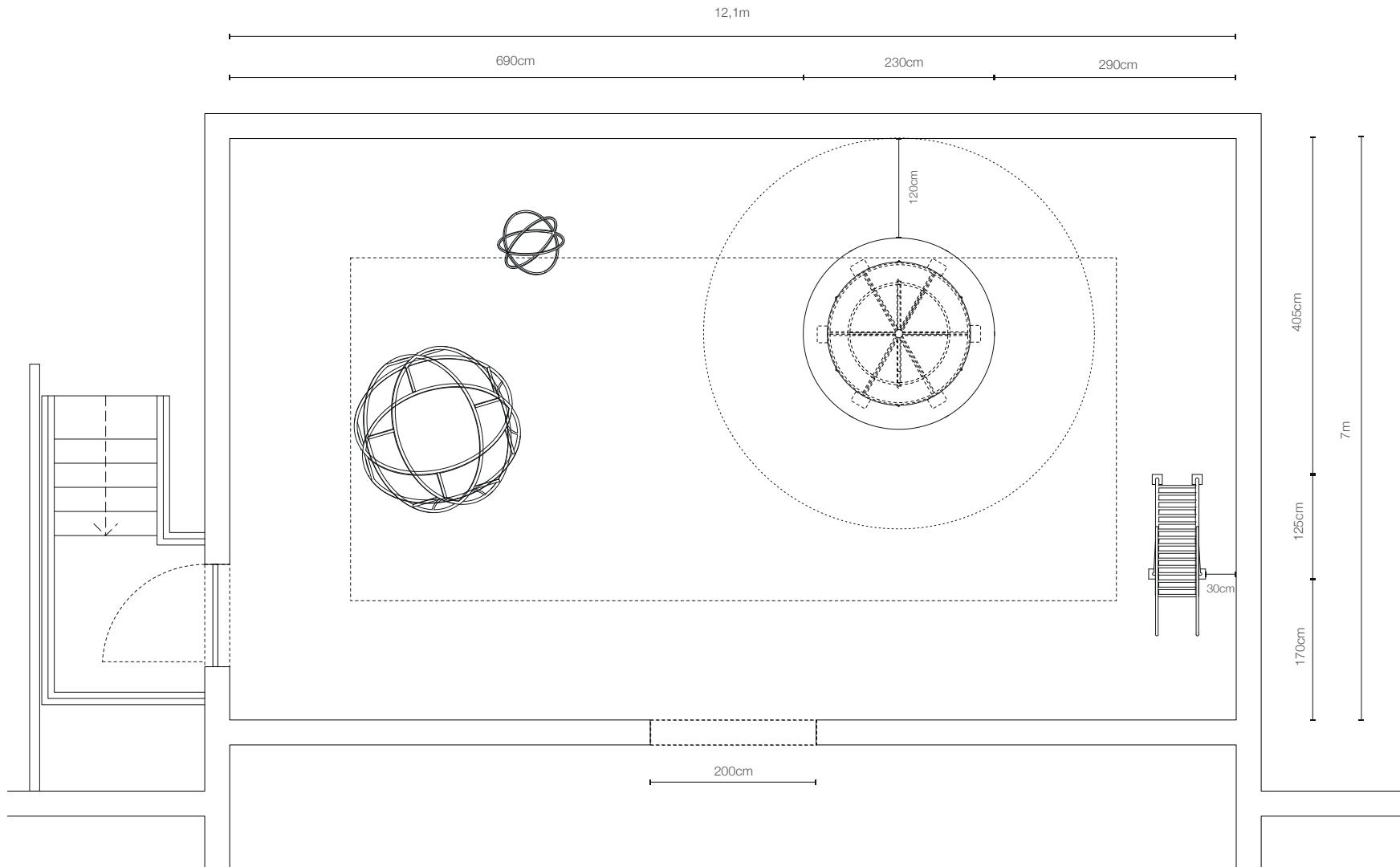

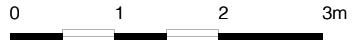

Salle de gauche
71m²

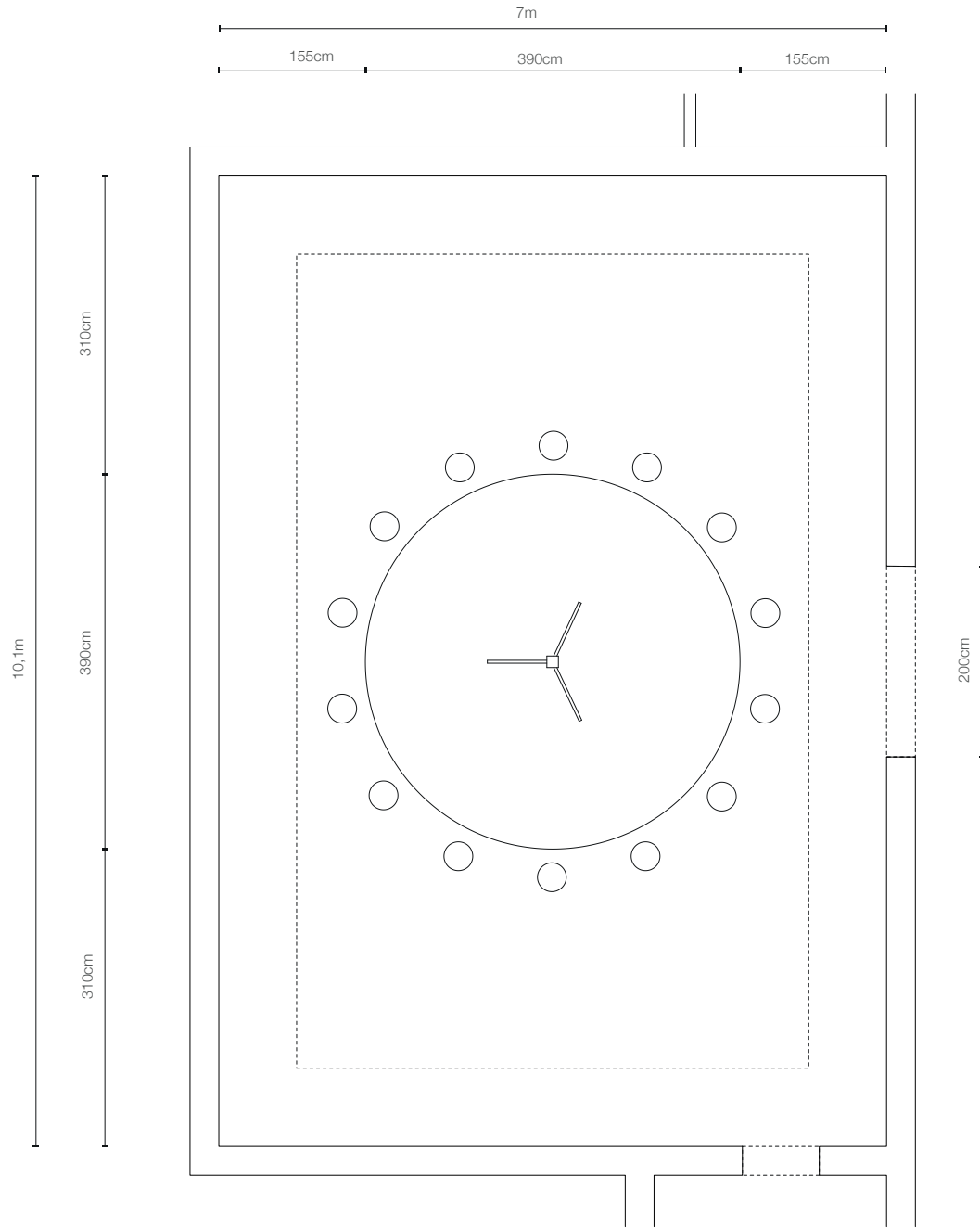



Salle de droite
71m²

